

Diesel Exhaust Thermometer, with Capillary Line



Crimped-on ring case stainless steel

Diesel exhaust thermometers are primarily used for the measurement of exhaust and cooling water temperatures at diesel engines. They are specially designed for these high mechanical and technical loads, among others due to the "stem in jacket version" and the standard case filling with highly viscous silicone oil. To increase their durability, diesel exhaust thermometers should always be applied in combination with a thermowell.

Standard Versions

This data sheet contains detailed information on our standard versions and available options. In overview 8000 you will find additional information on selection, metrological features, permissible ambient and storage temperatures as well as error limits, etc. Information on the metrologically optimal design of thermometers can be found in our technical information sheet T08-000-031.

Measuring Unit

With nitrogen filling (inert gas, physiologically safe)

Accuracy (DIN EN 13 190)

Class 1

Case

With polished crimped-on ring, stainless steel 304 (1.4301)

Degree of Protection (DIN EN 60 529/IEC 529)

IP65

Case Filling

Silicone oil

Nominal Case Sizes

63, 80, 100 mm (2½, 3, 4")

Case Configuration

Connection temperature sensor (stem):

- capillary line

Capillary line position:

- vertical bottom position

- centre back position (rm)

Mounting device:

- for bottom capillary line position:

- back flange for surface mounting (Rh)

- mounting device for gauge holder bracket (Mgh)

- for centre back capillary line position:

- u-clamp for panel mounting (rmBFr)

- back flange for surface mounting (rmRh)

Capillary Line

1 m (3.28') stainless steel Ø 2 mm (0.08")

with buckle protection tube at both ends

capillary line length L_{FL} selectable from 1 m to 15 m (3.28 to 49.21')

Temperature Ranges

0 – 120 °C (32 – 248 °F)

50 – 650 °C (122 – 1202 °F)

Temperature Sensor (Stem)

Made of stainless steel 316Ti (1.4571)

Max. static operating pressure: 25 bar

Stem models (jacket version): A5.5, A1.5 or A3.5

Stem Ø dF: 10, 12 or 13 mm (0.39, 0.47 or 0.51")

Stem length (standard): 150, 200, 250, 300 or 400 mm

(5.91, 7.87, 9.84, 11.81 or 15.75")

Compression fitting

for stem model A5.5: galvanised steel



Window

Instrument glass

Movement

Brass/German silver

Dial

0 – 120 °C aluminum white, scale black

50 – 650 °C aluminum natural finish, scale black

Pointer

Aluminum black

Indication Adjustment (±6 %)

Externally via screw

Ordering Information, Standard Ranges, Options

See page 4

Special Versions and Further Options

- Other stem lengths and connection threads upon request
- Version for particularly extreme loads
- Capillary line $F_{FL} > 15$ m upon request
- Other temperature ranges and/or special scales, e.g. dual scale °C/°F, coloured fields or ranges, dial inscriptions
- Case parts stainless steel 316L (1.4404) upon request
- Position of connection radial at 3 o'clock, 9 o'clock, 12 o'clock, others upon request or other than vertical installation (90°)
- GOST version for Russia, Kazakhstan

Thermowells

See data sheets 8.8110ff.



ARMANO Messtechnik GmbH

8292

Capillary Line Position, Code Letters, Dimensional Data and Weights

Vertical Bottom Capillary Line Position

mounting device for gauge holder bracket¹⁾
code letters **Mgh**

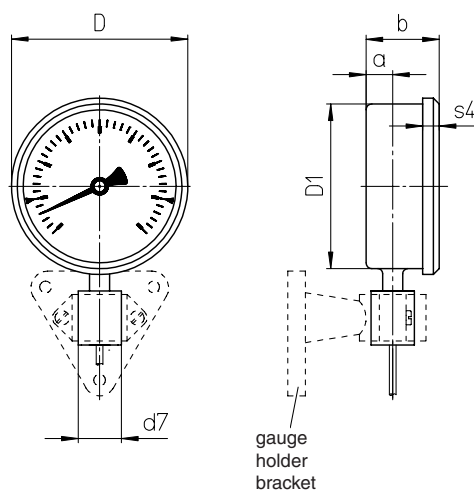

back flange for surface mounting
code letters **Rh**

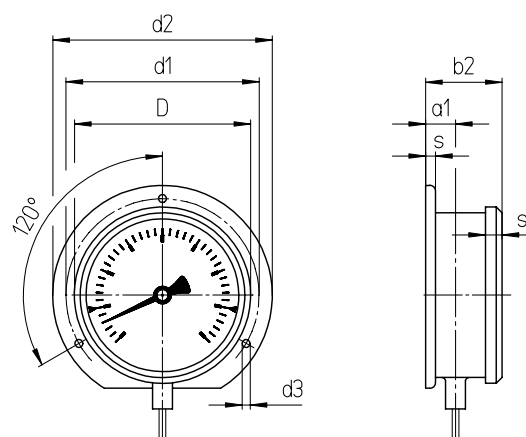

Centre Back Capillary Line Position

u-clamp for panel mounting
code letters **rmBFr**

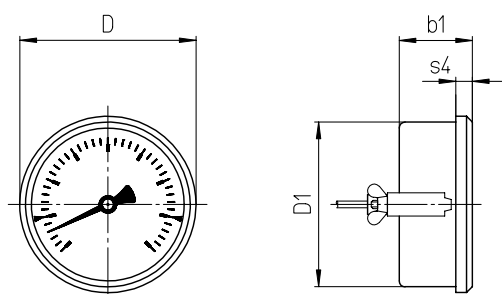

back flange for surface mounting (except NCS 80)
code letters **rmRh**

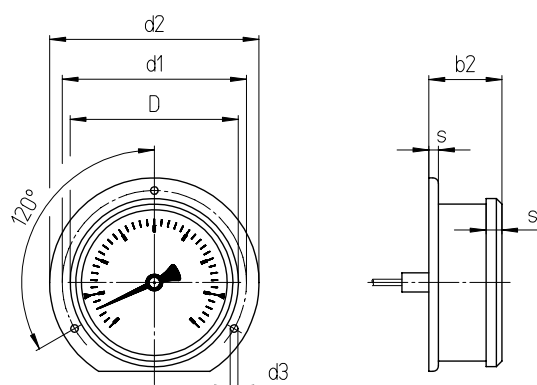

Dimensional Data (mm/inch) and Weights (kg/lb)

NCS	a	a1	b	b1	b2	D	D1	d1	d2	d3	d7	s	s4	approx. weight ²⁾ TAF
63 2½"	12 0.47	15 0.59	39 1.54	39 1.54	42 1.65	67 2.64	62 2.44	75 2.95	85 3.35	3.6 0.14	26 1.02	5 0.2	8 0.31	0.45 0.99
80 3"	15 0.59	18 0.71	42 1.65	42 1.65	45 1.77	86 3.39	79 3.11	95 3.74	110 4.33	4.8 0.19	26 1.02	5 0.2	8 0.31	0.6 1.32
100 4"	15 0.59	18.5 0.73	43 1.69	43 1.69	46.5 1.83	106 4.17	99 3.9	116 4.57	132 5.2	4.8 0.19	26 1.02	5 0.2	10 0.39	0.78 1.72

¹⁾ Available versions can be found on our website in section Product Range, heading Accessories.

²⁾ The data are examples and relate to the version with mounting device for gauge holder bracket Mgh and stem A1.5, Ø 10 mm (0.39"), length 200 mm (7.87") and 1 m (3.28") capillary line.

Stem Models

Stem Models

Process connection: Without screw fitting, plain stem

Stem model: A1.5
Form acc. to DIN EN 13 190: Form 1
Stem material: 1.4571
Stem Ø dF: 10, 12, 13 mm
Order length L (standard length): 150, 200, 250, 300, 350, 400 mm

Suitable thermowell models: SK2 (8.8141)
 (data sheet)

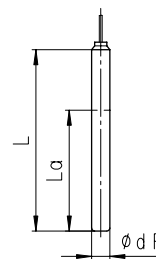

Process connection: Union nut

Stem model: A3.5
Form acc. to DIN EN 13 190: Form 5
Stem material: 1.4571
Stem Ø dF: 10, 12, 13 mm
Screw fitting material: 1.4571
Order length L (standard length): 150, 200, 250, 300, 350, 400 mm

Suitable thermowell models: SF4F (8.8112), SF4.1F (8.8113)
 (data sheet) SF9 (8.8131)

Thread (dimensional data in mm/inch):	G	SW	i
	G 1/2	27 / 1.06	10 / 0.39
	G 3/4	32 / 1.26	12 / 0.47
	M20x1.5	27 / 1.06	10 / 0.39
	M27x2	32 / 1.26	12 / 0.47

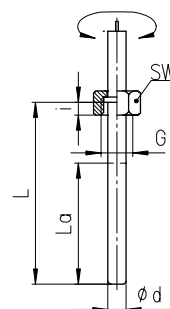

Process connection: Male thread/compression fitting

Stem model: A5.5
Form acc. to DIN EN 13 190: Form 2
Stem material: 1.4571
Stem Ø dF: 10, 12, 13 mm
Screw fitting material: galvanised steel
Order length L (standard length): 150, 200, 250, 300, 350, 400 mm

Suitable thermowell models: SF4 (8.8110), SF4F (8.8112)
 (data sheet) SF6, SF7 (8.8121)

Thread (dimensional data in mm/inch):	G	SW1	i	Lk
	G 1/2B	27 / 1.06	14 / 0.55	35 / 1.38
	G 3/4B	32 / 1.26	16 / 0.63	37 / 1.46
	M20x1.5	27 / 1.06	14 / 0.55	35 / 1.38
	M27x2	32 / 1.26	16 / 0.63	37 / 1.46

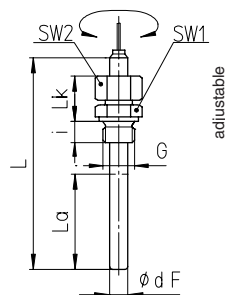

Stem Ø	SW2
10 / 0.39	19 / 0.75
12 / 0.47	22 / 0.87
13 / 0.51	24 / 0.94

Minimum Stem Length and Active Length (mm/inch)

Stem model:	Capillary line incl. stem ≤ 5 m (≤16.4')		Capillary line > 5 m (>16.4')	
	Length:		Length:	
	La	Lmin	La	Lmin
A1.5	80 / 3.15	150 / 5.91	120 / 4.72	175 / 6.89
A3.5	80 / 3.15	150 / 5.91	120 / 4.72	150 / 5.91
A5.5	80 / 3.15	150 / 5.91	120 / 4.72	175 / 6.89
others	upon request			

The minimum length Lmin is the smallest feasible stem length.

Important: Please note the technical information sheet T08-000-031 on the metrologically optimal stem length.

The active length La is the temperature-sensitive part of the stem.

